

# Wonder-Gun W301-ES-22-TC Specifications

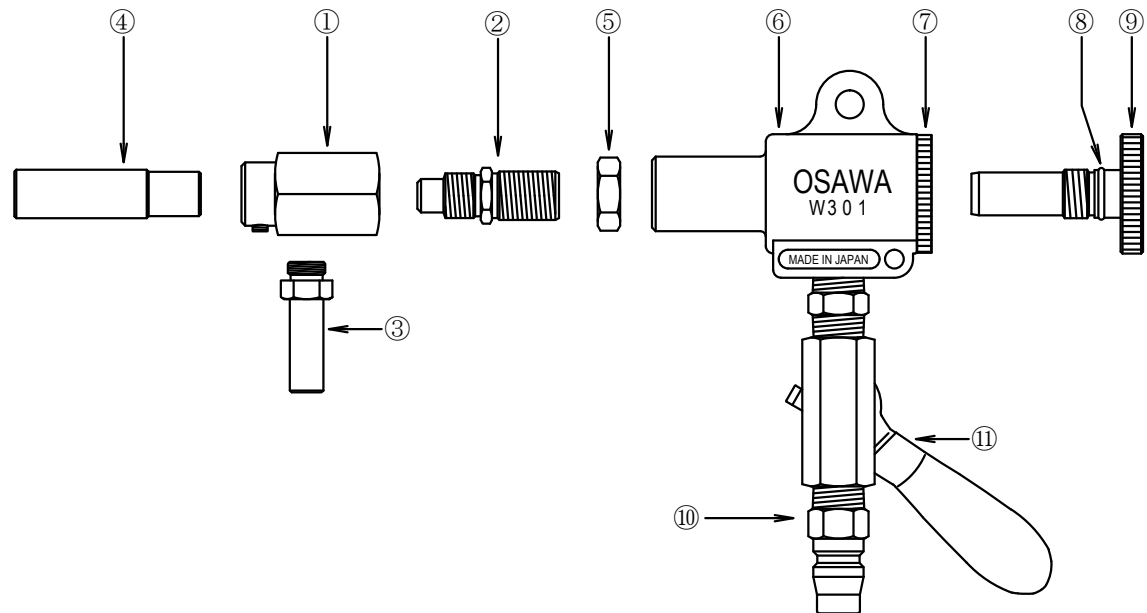

①~⑤ make Unit Assembly.

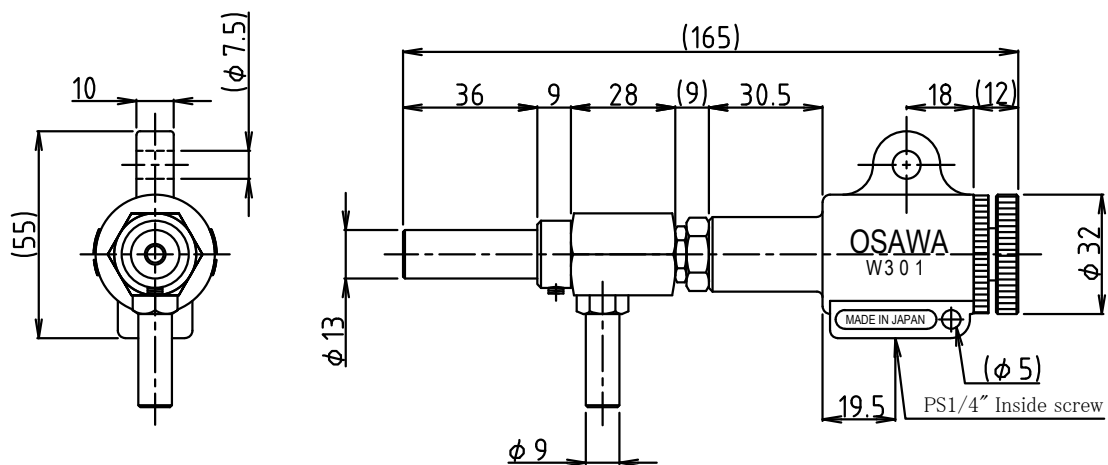

⑪	Ball valve	Brass 1/4"
⑩	Air coupler	Iron (Chrome plating)
⑨	Air adjustment knob	Aluminium
⑧	O ring	NBR S-10
⑦	Set column	Aluminium
⑥	Wonder-Gun body	Aluminium alloy •ADC-12
⑤	Nut	Brass (Chrome plating)
④	Jet nozzle	Iron •SK4 (Quench hardening)
③	Suction nozzle	Stainless •SUS304
②	Air jet nozzle	Stainless •SUS304
①	Unit main body	Stainless •SUS304
Name of article		Material • Summaries

Customer:		Issue Date
Description:	Drawn by:	
	Directed by:	
	Approval:	
Drawing date:	Scale:	Drawing Number
2008/11/27	--	ESI-10105-2