

Wonder-Gun W301-II-TC Specifications

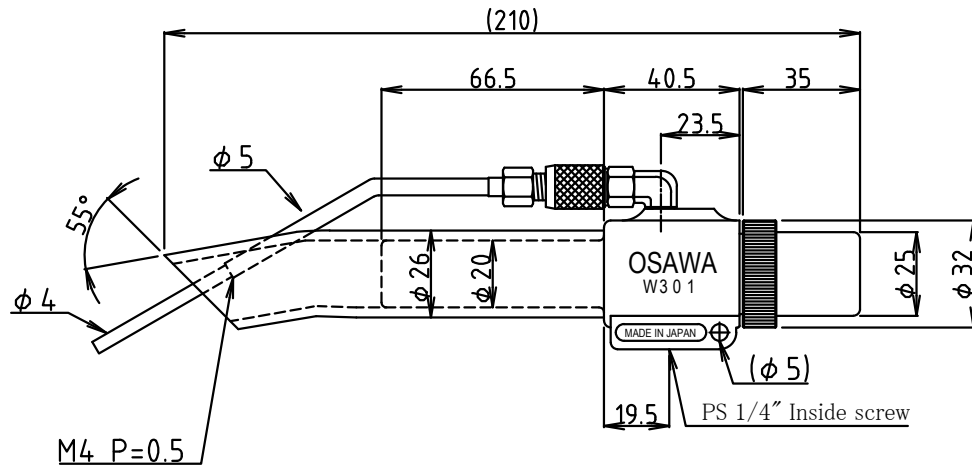
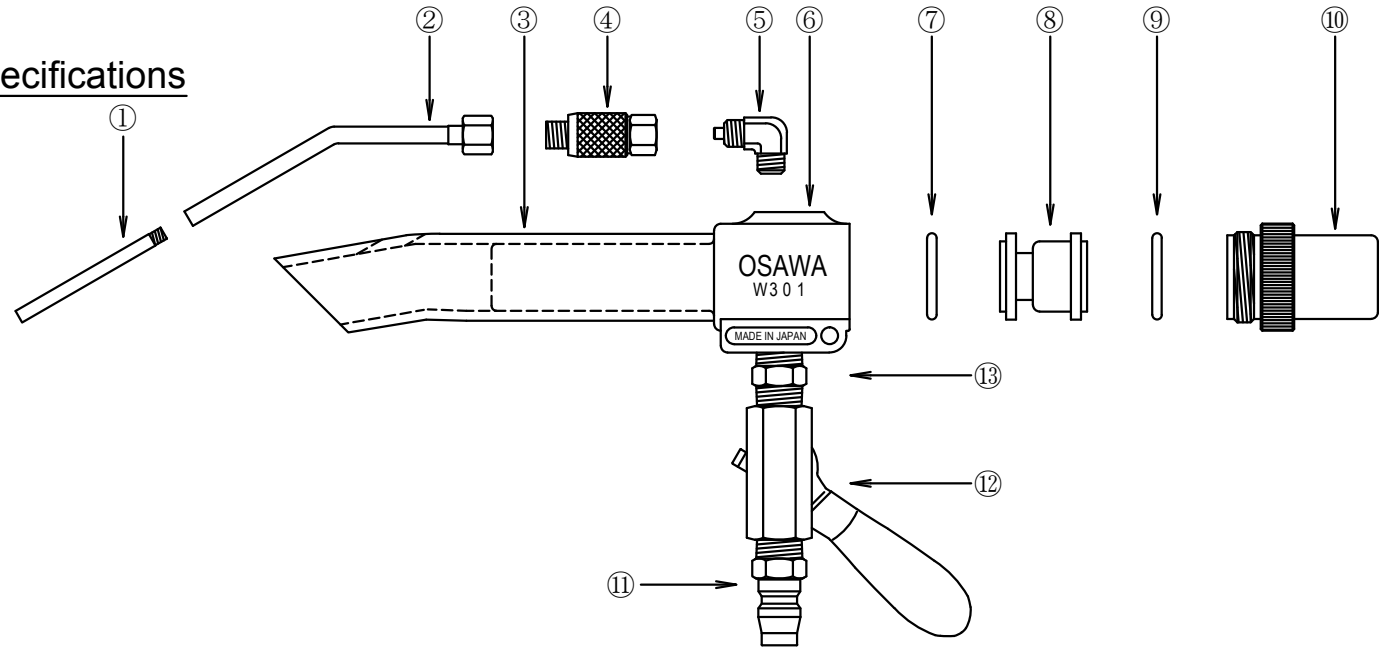

⑬	Nipple	Brass 1/4"
⑫	Ball valve	Brass 1/4"
⑪	Air coupler	Iron (Chrome plating)
⑩	Set column	Aluminum (Anodic oxide coating)
⑨	O ring	NBR P-22
⑧	Suction nozzle	Aluminum
⑦	O ring	NBR P-22
⑥	Wonder-Gun body	Aluminum • ADC-12
⑤	Air blow nozzle elbow	Brass (Chromate conversion coating)
④	Air adjustment valve	Brass (Chromate conversion coating)
③	Suction pipe	Transparent PVC
②	Air blow nozzle	Brass (Chromate conversion coating)
①	Air blow nozzle tip	Brass (Chrome plating)
	Name of article	Material • Summaries

Customer:		Issue Date
Description:	Drawn by:	
	Directed by:	
	Approval:	
Drawing date:	Scale:	Drawing Number
2008/06/19	--	ESI-10117-2