

# Jumbo model J-75 Specifications

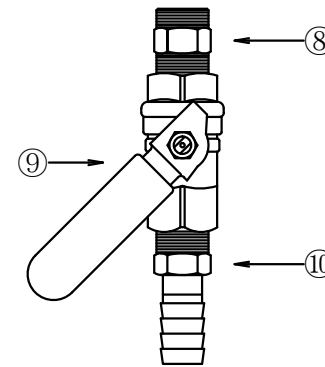
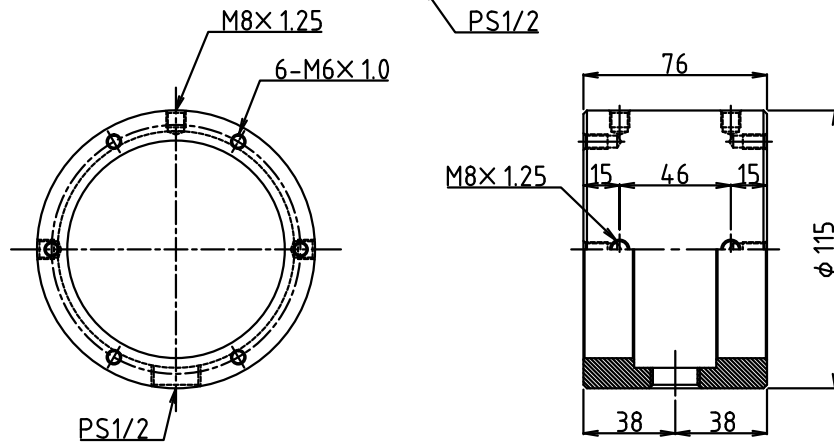
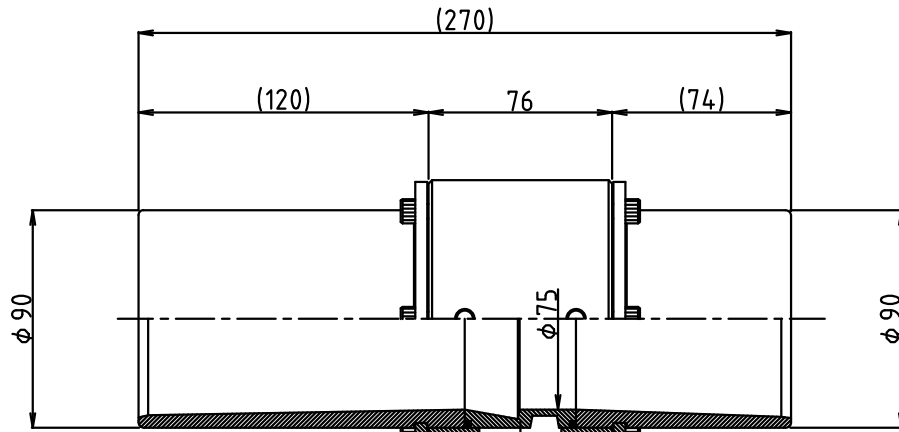
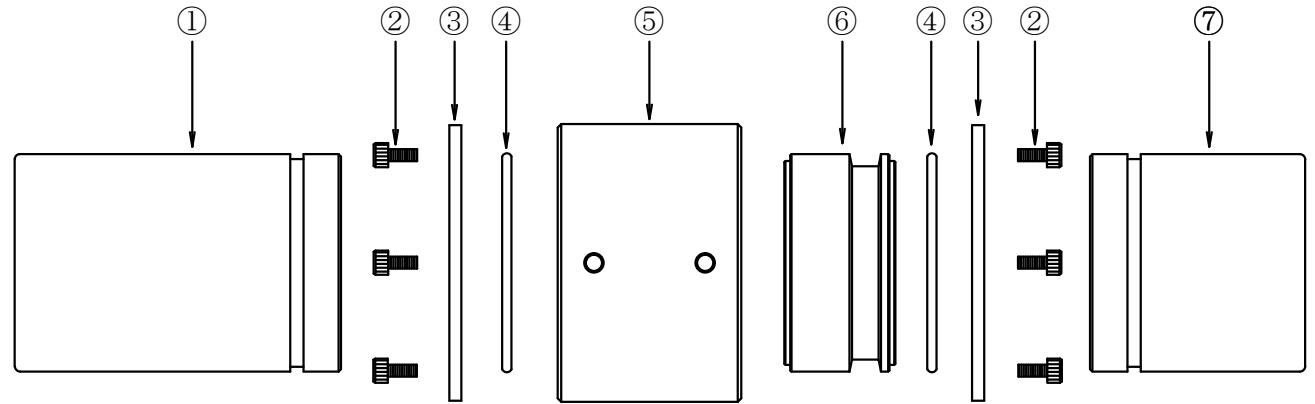

⑩	Hose joint	Brass 1/2" × 20.5 (3/4") (Nickel plating)
⑨	Ball valve	Brass 1/2" full bore
⑧	Nipple	Brass 1/2" (Nickel plating)
⑦	Suction pipe	Aluminum (Anodic oxide coating)
⑥	Suction nozzle	Aluminum (Anodic oxide coating)
⑤	Wonder-Gun body	Iron · S45C (Chrome plating)
④	O ring	NBR G-85
③	Washer	Iron (Chrome plating)
②	Bolt	Iron (Chromate conversion coating)
①	Delivery pipe	Aluminum (Anodic oxide coating)
Name of article		Material · Summaries

Customer:		Issue Date
Description:	Drawn by:	
	Directed by:	
	Approval:	
Drawing date: 2008/04/25	Scale: --	Drawing Number ESI-97019-1