

# Wonder-Gun W301-III -TH Specifications

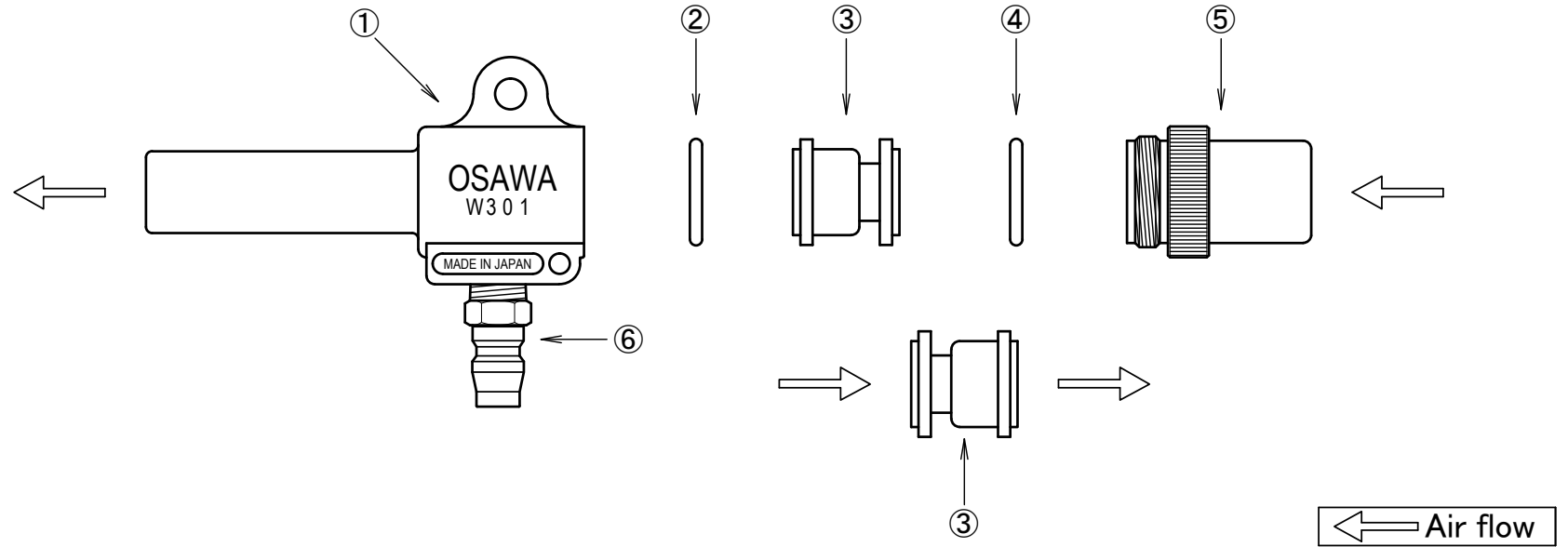

③ To change the direction of air flow, just reposition the suction nozzle. Please confirm the direction before operation.

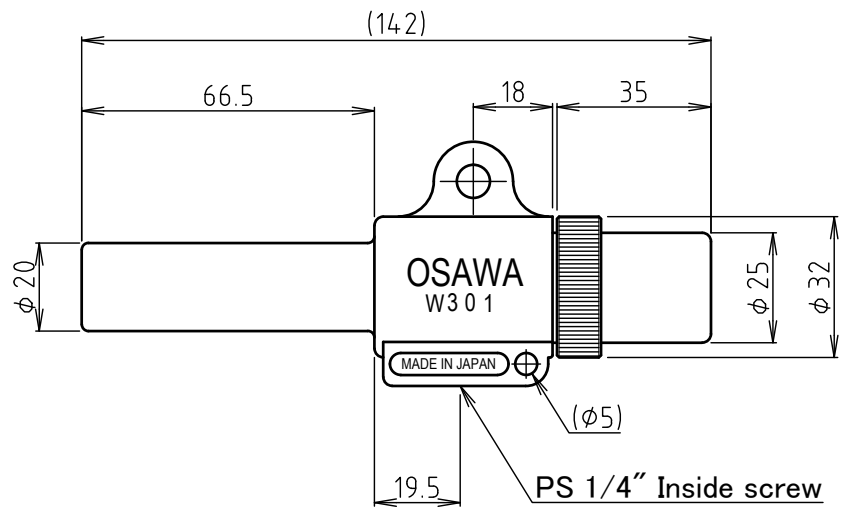
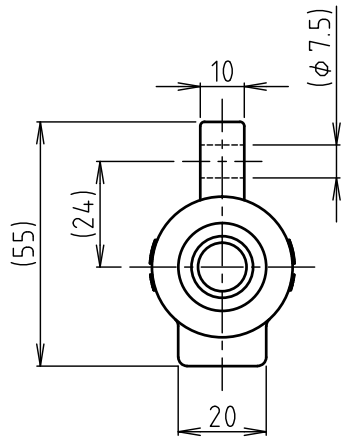

Name of article		Material	Summaries
⑥	Air coupler	Iron (Chrome plating)	
⑤	Set column	Aluminum (Anodic oxide coating)	
④	O ring	NBR P-22	
③	Suction nozzle	Aluminum	
②	O ring	NBR P-22	
①	Wonder-Gun	Aluminum alloy • ADC-12	
Customer:		Issue Date	
Description:		Drawn by:	
		Directed by:	
		Approval:	
Drawing date:	Scale:	Drawing Number	
2015/10/08	--	ESI-17001-2	