

Wonder-Gun W301-III -TC Specifications

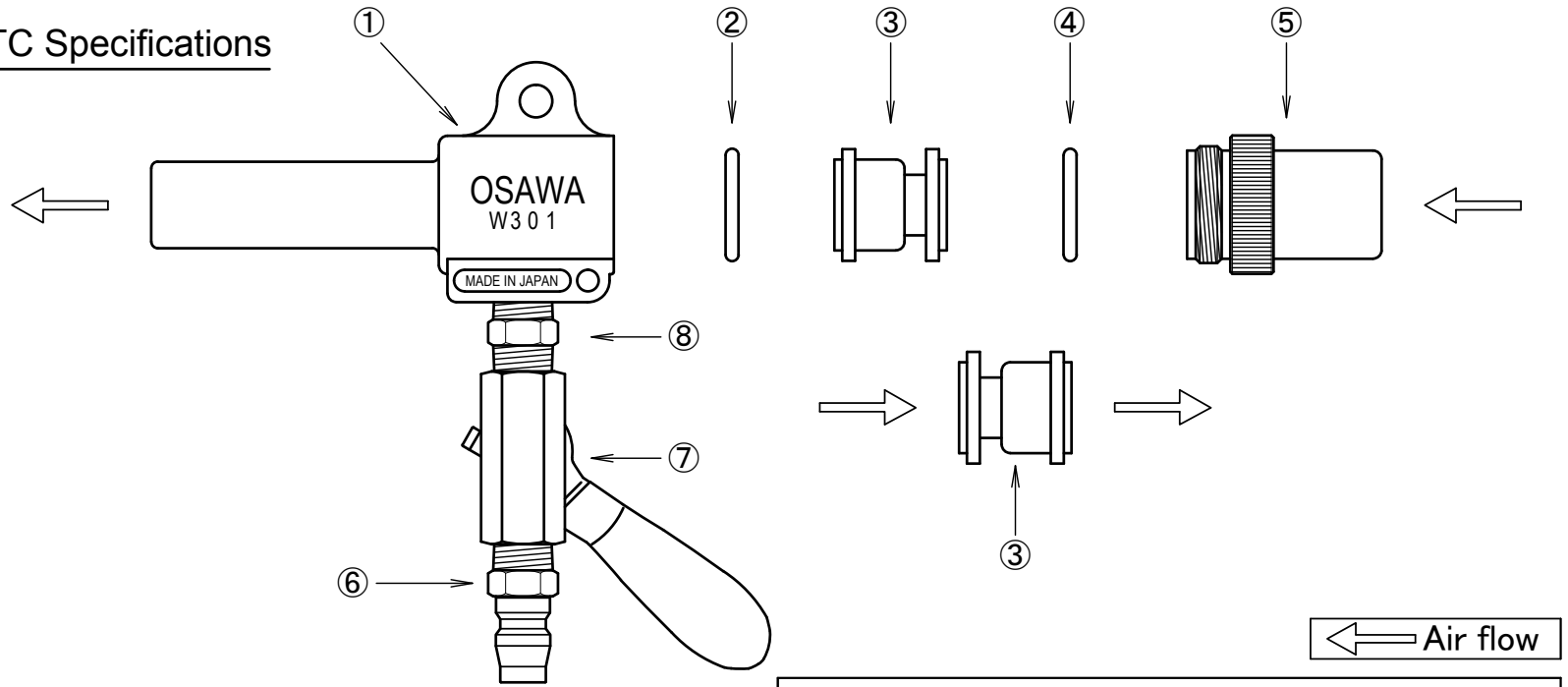

← Air flow

③ To change the direction of air flow, just reposition the suction nozzle. Please confirm the direction before operation.

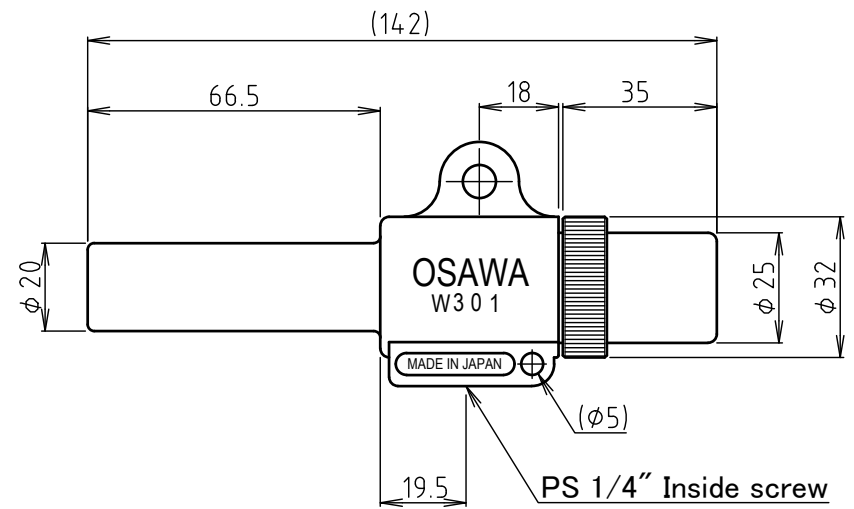
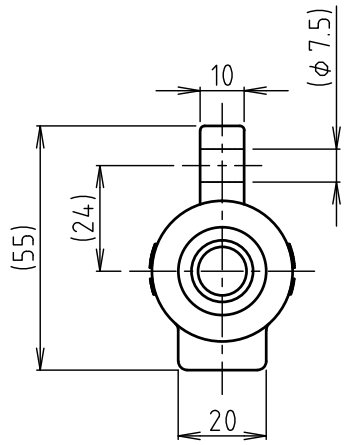

⑧	Nipple	Brass 1/4"
⑦	Ball valve	Brass 1/4"
⑥	Air coupler	Iron (Chrome plating)
⑤	Set column	Aluminum (Anodic oxide coating)
④	O ring	NBR P-22
③	Suction nozzle	Aluminum
②	O ring	NBR P-22
①	Wonder-Gun	Aluminum alloy • ADC-12
Name of article		Material • Summaries

Customer:		Issue Date	
Description:	Drawn by:		
	Directed by:		
	Approval:		
Drawing date:	Scale:	Drawing Number	
2015/10/08	--	ESI-17002-2	