

Wonder-Gun YW501-L YW501-LG Specifications

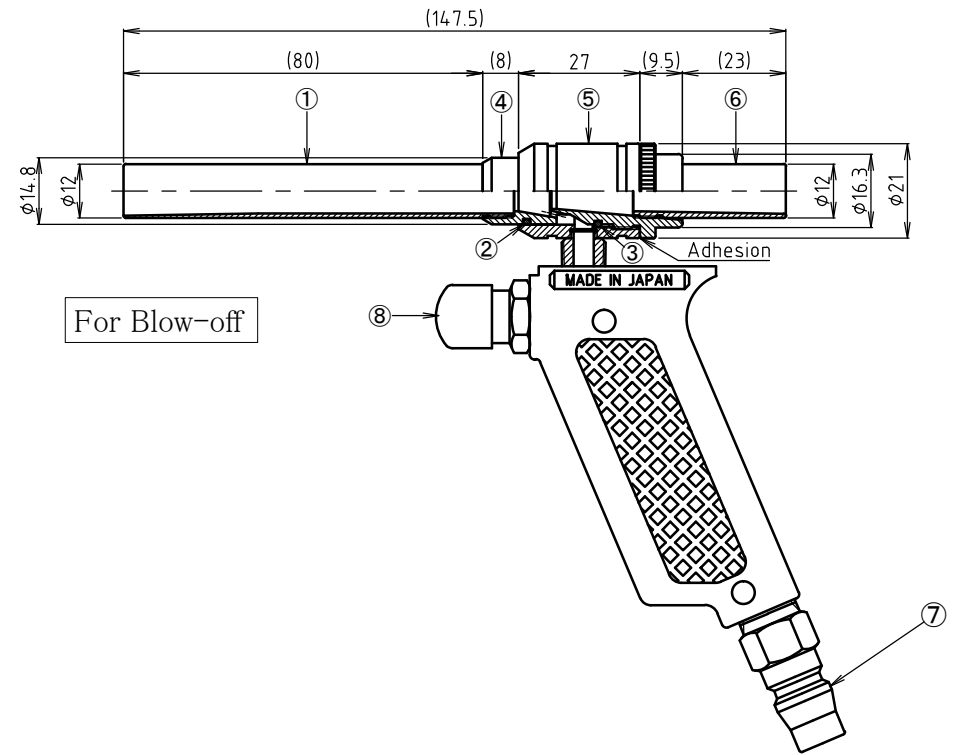
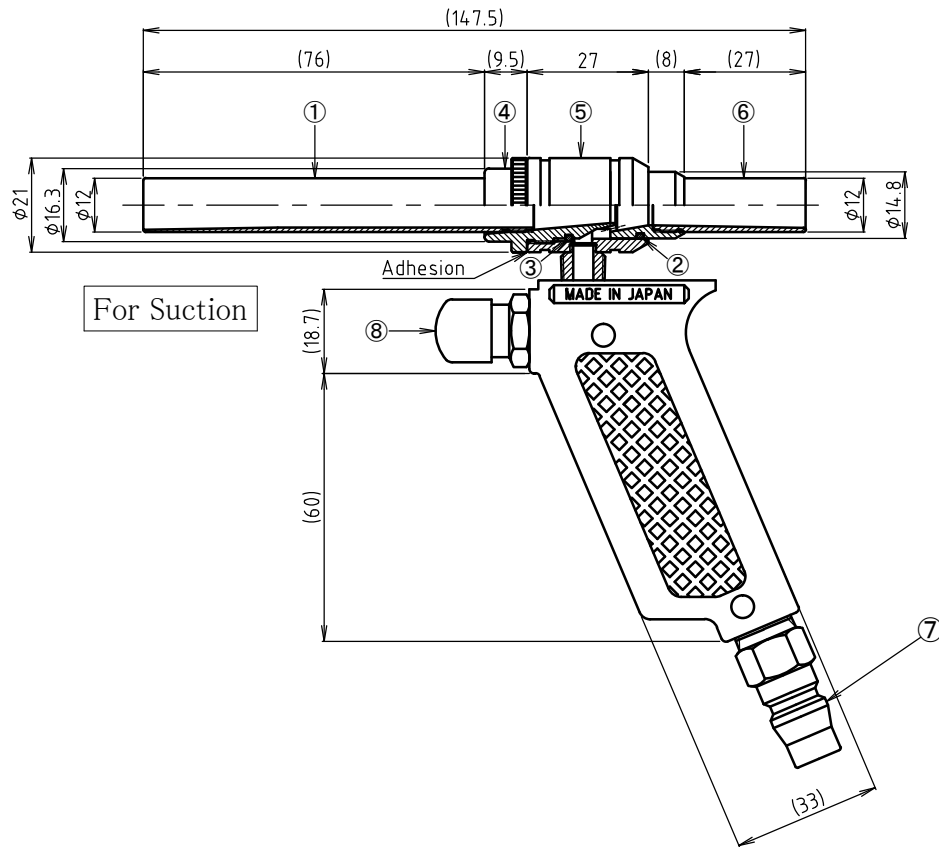

⑧	Air valve	Brass (Chrome plating)
⑦	Air coupler	Iron (Chrome plating)
⑥	Nozzle (S)	Brass (Yellow chromate conversion coating)
⑤	Sleeve	Brass (Yellow chromate conversion coating)
④	Wonder-Gun body	Brass (Yellow chromate conversion coating) Minimum ID: φ 8
③	O ring	NBR S-12.5 1piece
②	O ring	NBR S-11.5 1piece
①	Nozzle (L)	Brass (Yellow chromate conversion coating)
	Nozzle orifice	YW501-L φ 1.3×3 holes YW501-LG φ 1.3×6 holes
	Weight	240g

YW501-S • YW501-SG is used for Blow-off version or Suction version.
Please make sure which version you need when you order.

Name of article		Material • Summaries	
Customer:			Issue Date
Description:		Drawn by:	
		Directed by:	
		Approval:	
Drawing date:	Scale:	Drawing Number	
2018/12/14	--	ESI-97055-2	