

Wonder-Gun W301-ES-26-LH Specifications

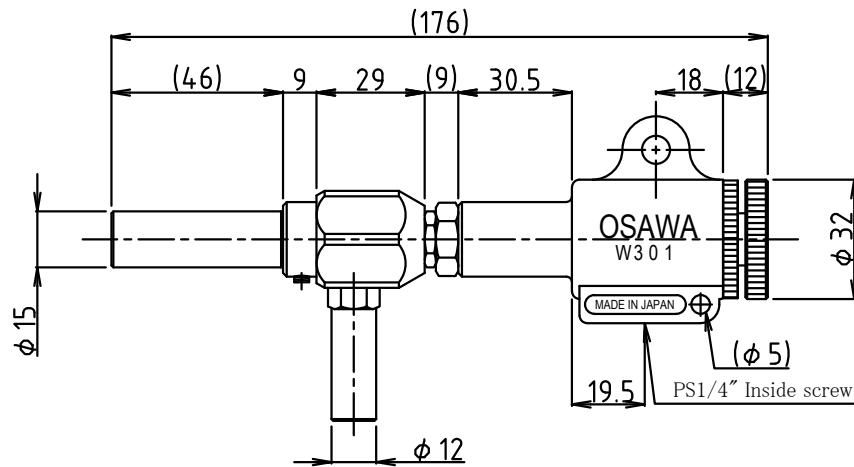
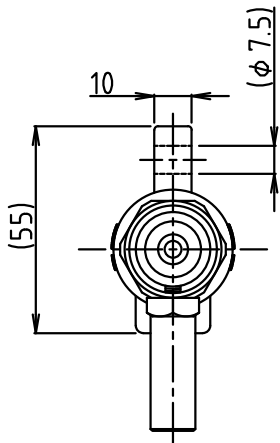
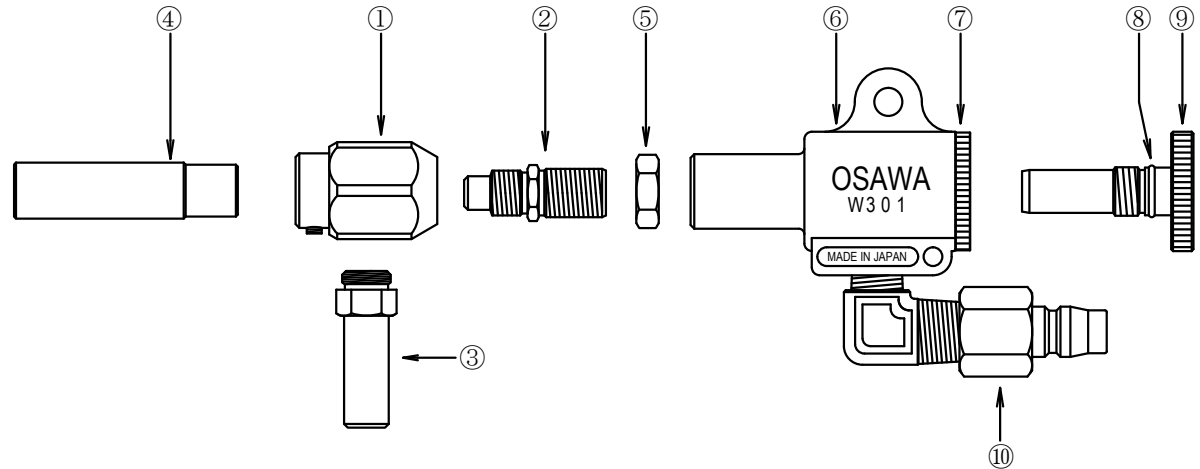

①~⑤ make Unit Assembly.

	Name of article	Material • Summaries
⑩	Air coupler	Iron (Chrome plating)
⑨	Air adjustment knob	Aluminium
⑧	O ring	NBR S-10
⑦	Set column	Aluminium
⑥	Wonder-Gun body	Aluminium alloy •ADC-12
⑤	Nut	Brass (Chrome plating)
④	Jet nozzle	Iron •SK4 (Quench hardening)
③	Suction nozzle	Stainless •SUS304
②	Air jet nozzle	Stainless •SUS304
①	Unit main body	Stainless •SUS304
	Name of article	Material • Summaries

Customer:		Issue Date
Description:	Drawn by:	
	Directed by:	
	Approval:	
Drawing date: 2008/06/24	Scale: --	Drawing Number ESI-10110-2