

Mini-Porter-Cyclone

MP-50WA CF20 Specifications

2008/08/25

| Item | Contents |
|-----------------------|--|
| ① Hose | Soft polyvinyl chloride(ID φ 38×400mm) |
| ② Lid stopper | Stainless•SUS304 |
| ③ Packing | Silicon |
| ④ Silencer | External side: Iron(Chrome plating)/Inside: White cloth and Glass wool |
| ⑤ Lid stopper support | Stainless•SUS304 |
| ⑥ Cyclone body | Stainless•SUS304(connection: φ 50/ plate thickness: 2.0mm) |
| ⑦ Hose | Transparent PVC (ID φ 50×3000mm) |
| ⑧ MP lid | Aluminum alloy casting •AC4C Melamine resin baking finish |
| ⑨ Clasps | Iron (Chrome plating) Rivet (Aluminum) |
| ⑩ Suction pipe | Aluminum (OD φ 50×600mm) |
| ⑪ Tank | Transparent PVC 25 ℓ |
| ⑫ Stand | Aluminum alloy casting •AC4C Melamine resin baking finish |
| ⑬ Casters | Conductive casters/4 pieces (1 with a break) |
| ⑭ Filter | External side: Iron (Chrome plating)/Inside: Glass wool |
| O ring | NBR |
| Air pressure | 0.5~0.6MPa (5~6kg/cm ²) |
| Suction power | -0.0227~-0.0263MPa (2268~2632mmAq) |
| Air consumption | 236~275 ℓ /min Normal |

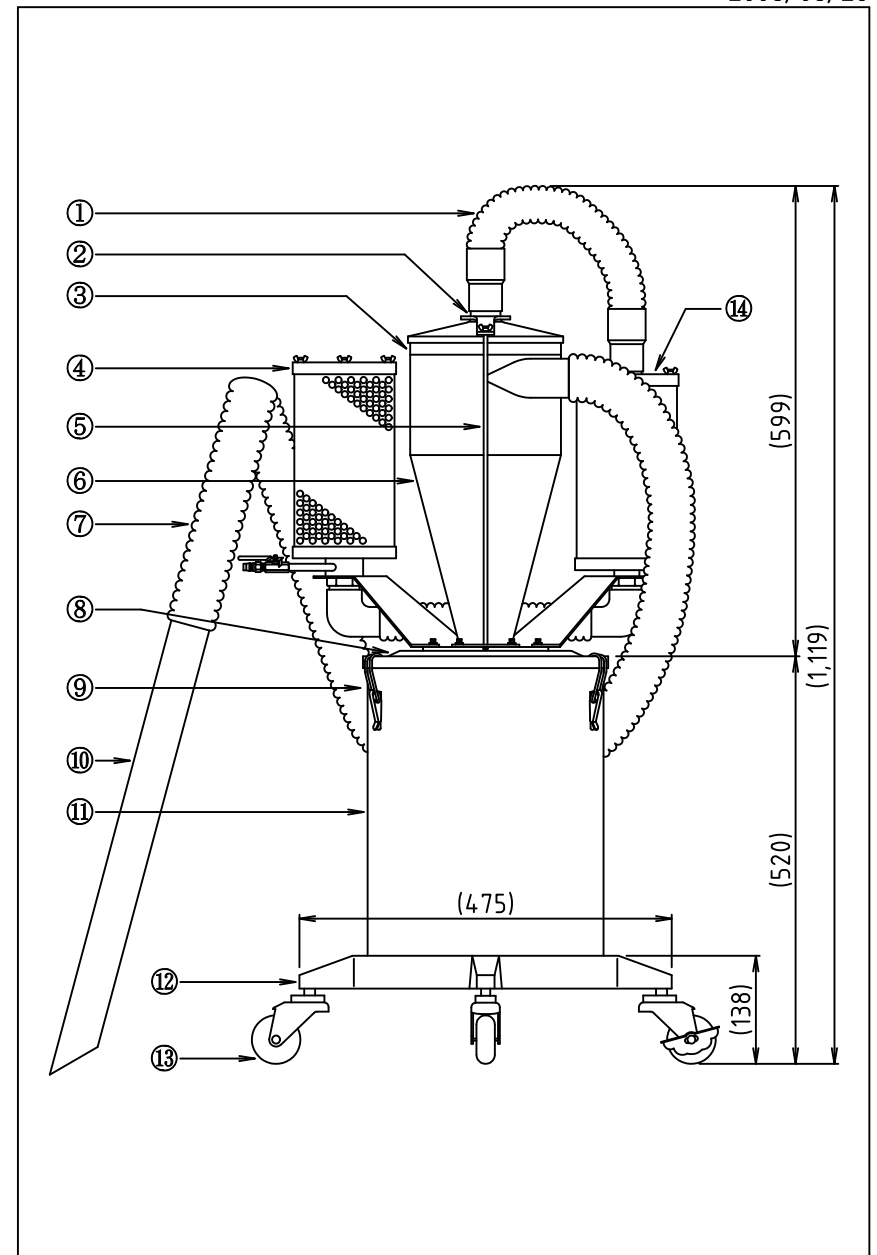

Remarks