

# Mini-Porter-Cyclone

## MP-50SWA CF20 Specifications

2011/02/15

Item	Contents
① Hose	Soft polyvinyl chloride(ID φ 38×400mm)
② Lid stopper	Stainless•SUS304
③ Packing	Silicon
④ Silencer	External side: Iron(Chrome plating)/Inside: White cloth and Glass wool
⑤ Lid stopper support	Stainless•SUS304
⑥ Cyclone body	Stainless•SUS304(connection: φ 50/ plate thickness: 2.0mm)
⑦ Hose	Transparent PVC (ID φ 50×3000mm)
⑧ MP lid	Aluminum alloy casting •AC4C Melamine resin baking finish
⑨ Clasps	Iron (Chrome plating) Rivet (Aluminum)
⑩ Suction pipe	Aluminum (OD φ 50×600mm)
⑪ Tank	Stainless•SUS304 30 ℓ
⑫ Stand	Aluminum alloy casting •AC4C Melamine resin baking finish
⑬ Casters	Conductive casters/4 pieces (1 with a break)
⑭ Filter	External side: Iron (Chrome plating)/Inside: Glass wool
O ring	NBR
Air pressure	0.5~0.6MPa (5~6kg/cm <sup>2</sup> )
Suction power	-0.0227~-0.0263MPa (2268~2632mmAq)
Air consumption	236~275 ℓ /min Normal

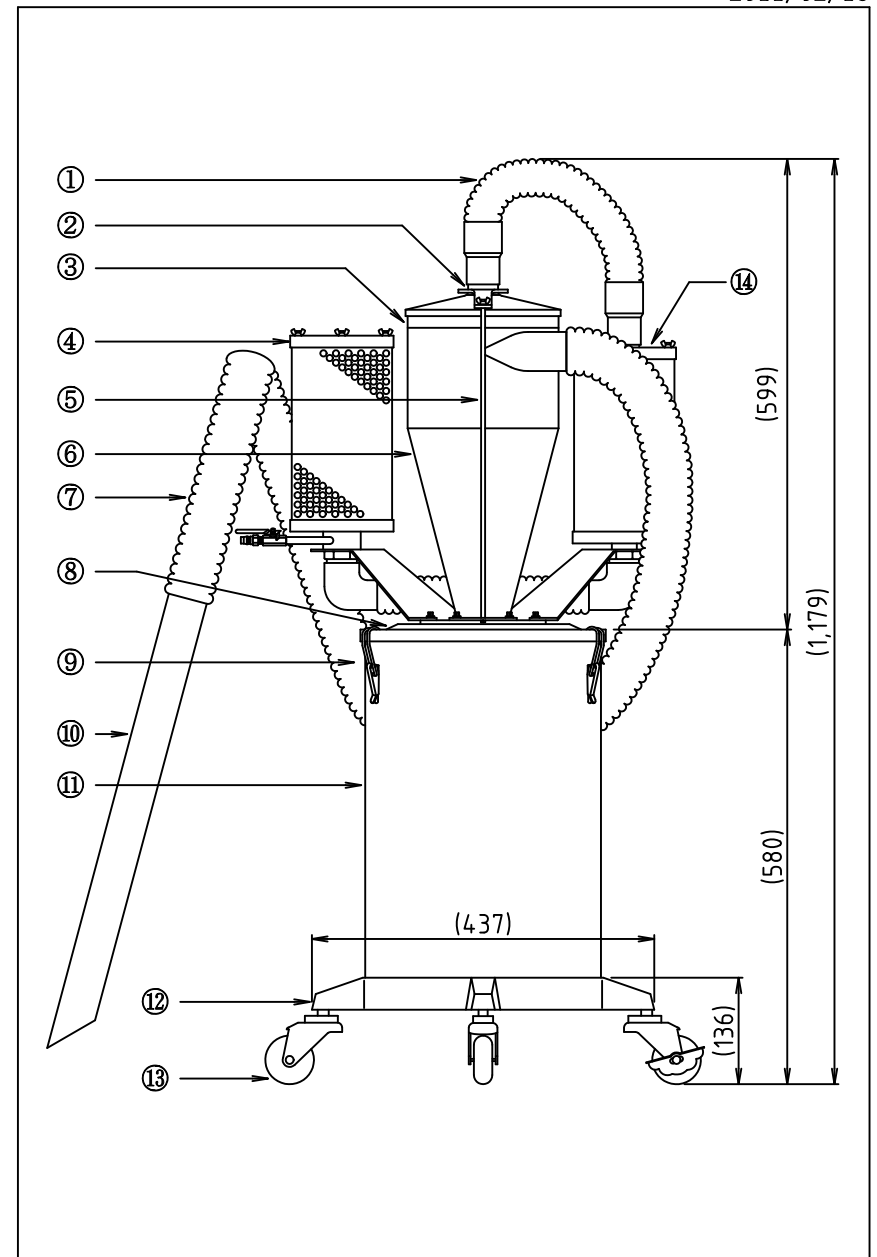

Remarks