

# Silent-Cleaner SC200-50DG W/F

## Instructions

- ① Please make sure the following parts are contained inside the package:
 

Silent-Cleaner .....	1
Suction Pipe.....	1
Hose .....	1
Hose Clamp .....	2
Spare Filter (for fine dust collection).....	1
  - ② Put the Silent-Cleaner on top of any available 200L open top drum and fasten well. (If there are any available bands attached with the open top drum, fasten well.)
  - ③ Attach the hose with the suction mouth of the Silent-Cleaner and fasten well with the hose clamp. (It can be made easier by turning the hose clockwise while attaching.)
  - ④ Connect the suction pipe with the hose and fasten well with the hose clamp. (It can be made easier by turning the hose clockwise while attaching.)
  - ⑤ Connect the air hose (ID over 19mm) with the Silent-Cleaner. For optimal performance, while connecting, please make sure that the air filter is present in between the connection to prevent rust entering into the device. Please make sure that the air valve is closed when connecting the air hose.
  - ⑥ Suction will start as soon as the air cock is turned open on the Silent-Cleaner.
- ★ Peep Hole can be easily taken off for inspection.
- ★ When the vacuum power is low, please check for the following:
- (1) If air pressure is at sufficient level, or air volume is sufficient.
  - (2) If the appropriate air hose is connected, not too long or too thin.
  - (3) Connecting with the minimum numbers of couplers, or connecting the inappropriate couplers lead to insufficient airflow and may not be able to maintain optimal performance.

### ★ Feature

Silent-Cleaner has the following extraordinary feature:

- The Safety valve prevents the sudden vacuum level increase when the suction mouth is blocked and avoids damage to the device or the drum.
- Please do not randomly adjust the safety valve to prevent any damage or danger.

### ★ Caution

- When the vacuum level decreases it indicates that the filters require replacement.

#### Fine Dust Filter

- The fine dust is caught at the cloth cover (exterior) primarily and then at the fine dust filter inside. Please replace the fine dust filter occasionally to prevent the filter from clogging causing excessive vacuum level at the suction area, or the dust flowing to the silent filter.

#### Silent Filter

- Please make sure to supply clean compressed air to prevent the silent filter from getting clogged with rust or oil in addition to the dust discharged through the fine dust filter.

Please take off the fine dust filter for the liquid suction.



TEL: +81-6-6572-1207

FAX: +81-6-6572-1256

E-mail: osawa@osawa-company.co.jp

In case you have any inquiry, please contact the dealer or the manufacturer.

## How to reassemble the filters

The Fine Dust Filter is preinstalled in this device. However, when dismantling the filter for cleaning or replacement, please reassemble in the following order:

- (1) Invert the Silent-Cleaner.
- (2) Push the bolt ① (shorter side) into the cleaner body.
- (3) Put the Punching Metal (Small) ⑤ & the Fine Dust Filter and Punching Metal (Large) ④ & the Cloth Cover (White) on the Silencer's body.
- (4) Fit the Filter Cover ③ with the bolt ① and fasten the Butterfly Nut ②.

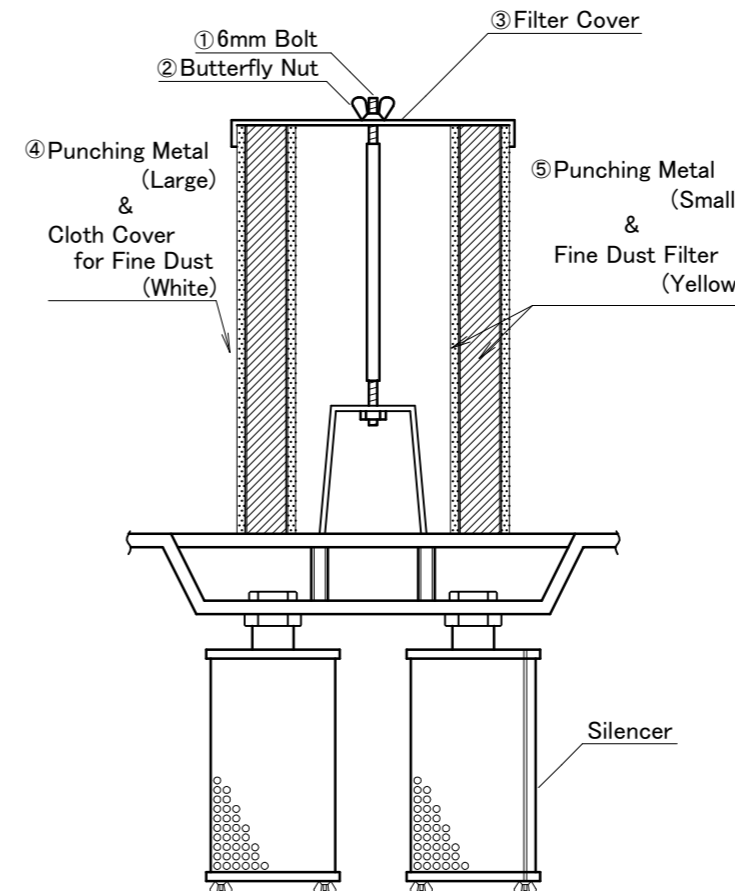

### Attention:

- When the vacuum level decreases, it indicates that the Cloth Cover ④ requires cleaning. Please clean the Cloth Cover occasionally. If the vacuum level is not regained, please replace the Fine Dust Filter ⑤.
- Please replace the Fine Dust Filter occasionally to prevent the excessive vacuum level at the suction area and the dust flowing to the Silent Filter.

### How to order the filters:

- To order the fine dust filter (Yellow), please specify as FINE DUST FILTER (Large) for SC200-50DG W/F, available from 6pcs in 1 set.
- To order the Cloth Cover for fine dust (White), please specify as CLOTH COVER FOR FINE DUST (Large), for SC200-50DG W/F, available from 2pcs in 1 set.
- Silent Filter is located inside the Silencer. Please specify as the SILENT FILTER (for all Silent-Cleaner models), available from 1pc.

## How to order the Hydro Stopper (Option)

- For the liquid suction, installing the Hydro Stopper will provide a good performance. The Hydro Stopper is the device to control the quantity of vacuuming liquid when the deposited liquid comes up to the preset level inside the drum, it automatically close the suction mouth to stop the liquid suction. To order the Hydro Stopper, please specify as HYDRO STOPPER. (for all Silent-Cleaner models), available from 1 set.