

Silent-Cleaner SC30-32TVG

Exclusive Type for Grease Suction

Instructions

- ① Please make sure the following parts are contained inside the package:
 - Silent-Cleaner (with Pressure Gauge) 1
 - Air Hose 5m (ID10mm x OD14.5mm)..... 1
 - 25L Transparent Tank with Caster stand 1
 - Casters (one with brake)..... 4
 - Spanner/ wrench for fastening casters..... 1
 - Suction pipe 1
 - Hose 1
 - Hose Clamp 2
 - Spare Filter (for dust collection) 1
 - ② Attach the casters with the caster stand at the bottom of 25L Transparent tank and fasten well with the spanner/ wrench.
 - ③ Put the Silent-Cleaner on top of the 25L Transparent tank and fasten with the draw latches.
 - ④ Attach the hose with the suction mouth of the Silent-Cleaner and fasten well with the hose clamp. (It can be made easier by turning the hose clockwise while attaching.)
 - ⑤ Connect the suction pipe with the hose and fasten well with the hose clamp. (It can be made easier by turning the hose clockwise while attaching.)
 - ⑥ Connect the air hose (ID over 10mm) with the Silent-Cleaner. For optimal performance, while connecting, please make sure that the air filter is present in between the connection to prevent rust entering into the device. Please make sure that the air valve is closed when connecting the air hose.
 - ⑦ Please keep the air pressure at the Silent-Cleaner's gauge over 0.37MPa during the operation. Suction will start as soon as the air cock is turned open on the Silent-Cleaner.
- ★ When the vacuum power is low, please check for the following:
- (1) Air pressure is at sufficient level, or air volume is sufficient.
 - (2) Connecting with the minimum numbers of couplers, or connecting the inappropriate couplers lead to insufficient airflow and may not be able to maintain optimal performance.
 - (3) Connect the air hose with ID over 10mm.
- ★ Caution
- When the vacuum level decreases it indicates that the filters require replacement.
 - Do not give any shock or drop the tank during the operation to prevent any damage to the tank, as the vacuum inside the tank is at high level.

Dust Filter

- Please replace the dust filter occasionally to prevent the filter from getting clogged, causing excessive vacuum level at the suction area, or the dust flowing to the silent filter.

Silent Filter

- Please make sure to supply clean compressed air to prevent the silent filter from getting clogged with rust or oil in addition to the dust discharged through the dust filter.

Please use the exclusive model for dust as this model is not designed for that purpose.

How to order the filters

- ① Silent Filter is located inside the Silencer.
Please specify as SILENT FILTER (for all Silent-Cleaner models), available from 1pc.
- ② To order the dust filter (Yellow), please specify as DUST FILTER (Small), available from 6pcs in 1 set.

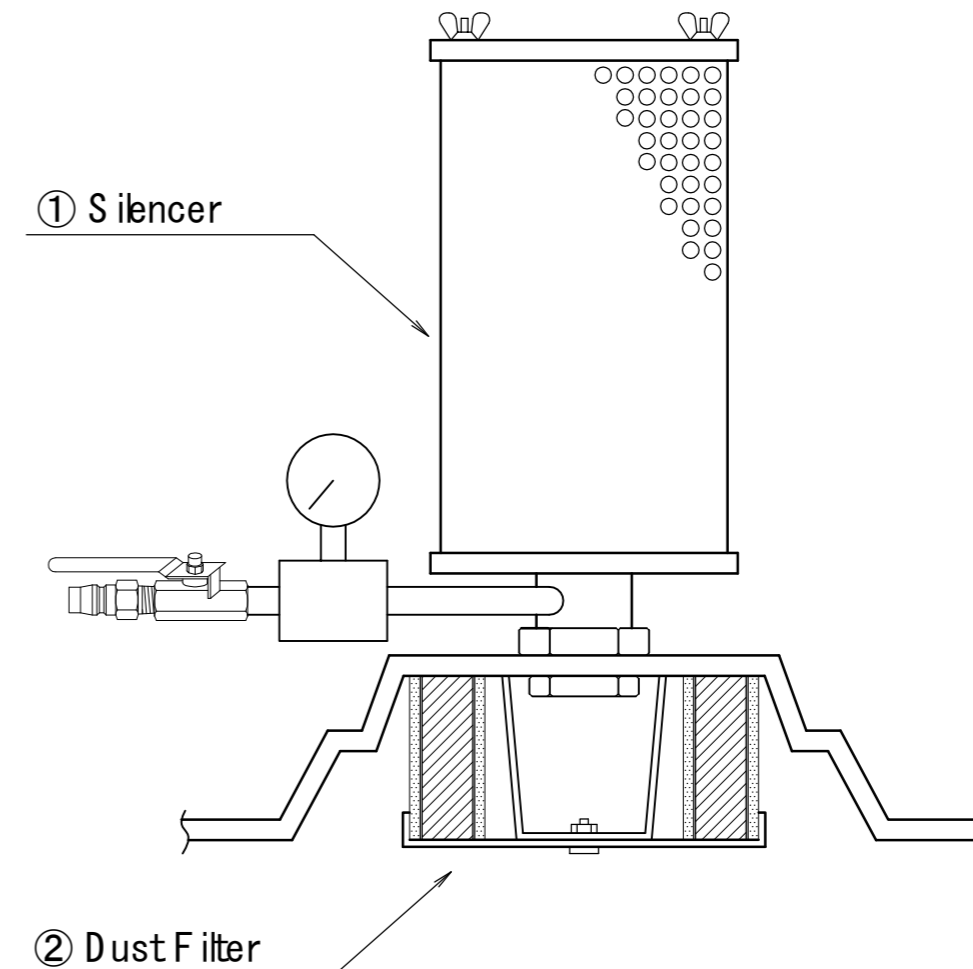

- Please use the exclusive model for collecting dust as this model is not designed for that purpose.

 **OSAWA & COMPANY**

TEL: +81-6-6572-1207

FAX: +81-6-6572-1256

E-mail: osawa@osawa-company.co.jp

In case you have any inquiry, please contact the dealer or the manufacturer.