

Mini-Porter-Cyclone MP-50WA CF20

Instructions

- ① Please make sure the following parts are contained inside the package:

Mini-Porter-Cyclone	1
25L Transparent Tank with Caster stand	1
Casters (one with brake)	4
Spanner/ wrench for fastening casters.....	1
Hose.....	1
Hose Clamp	2
Suction Pipe	1
Cap Stopper	1
Spare filter (Yellow)	1
 - ② Attach the casters with the caster stand at the bottom of 25L transparent tank and fasten well with the spanner/ wrench.
 - ② Attach the hose with the suction mouth on top of the Mini-Porter-Cyclone.
 - ③ Put the Cyclone on top of the transparent tank and fasten with the draw latches.
 - ⑤ Attach the hose with the suction mouth on the side of the Mini-Porter-Cyclone and fasten well with the hose clamp.
(It can be made easier by turning the hose clockwise while attaching.)
 - ⑥ Connect the suction pipe with the hose and fasten well with the hose clamp.
(It can be made easier by turning the hose clockwise while attaching.)
 - ⑦ Connect the air hose (ID over 8.5mm) with the Mini-Porter-Cyclone. For optimal performance, while connecting, please make sure that the air filter is present in between the connection to prevent the rust entering into the device.
Please make sure that the air valve is closed when connecting the air hose.
 - ⑧ Suction will start as soon as the vacuum cleaner is switched on. Then start the suction after waiting for 2 or 3 seconds till the airflow stabilizes. Vacuum the particles with the air when operating.
- ★ When the vacuum power is low, please check for the following:
- (1) Air pressure is at sufficient level, or air volume is sufficient.
 - (2) Connecting the appropriate air hose, not too long or too thin.
 - (3) Connecting with the minimum numbers of couplers, or connecting the inappropriate couplers lead to insufficient airflow and may not be able to maintain optimal performance.
- ★ Caution
- Please inspect and clean the transparent tank occasionally to prevent the vacuumed dust entering into the ejector and causing filter clogging.
 - Please make sure to supply clean compressed air or the silencer may get clogged with the rust or oil.
 - Please replace the filter and the silencer occasionally when the vacuum level is low since the clogged filter or silencer often causes lower vacuuming performance.
 - Please ground/ earth the device to control static electricity.
(Antistatic Hose is available for option.)

Cleaning Maintenance

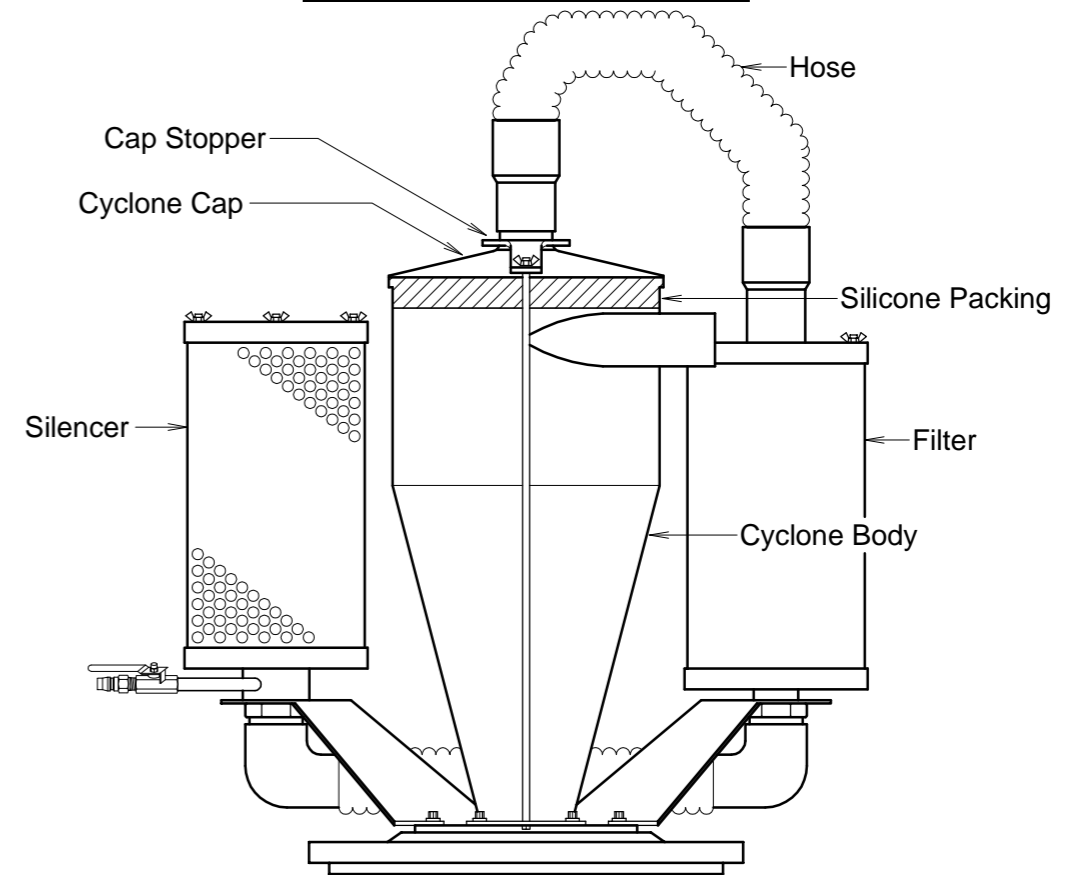

※ Frequent maintenance is not needed for Mini-Porter-Cyclone. However, occasional cleaning is required in the inside of the body to maintain optimal performance. To clean, brush the inside occasionally. Especially after vacuuming the moist dust, brush well or wipe well with the dry cloth since the moist dust stays inside.

How to take off the Cyclone Cap

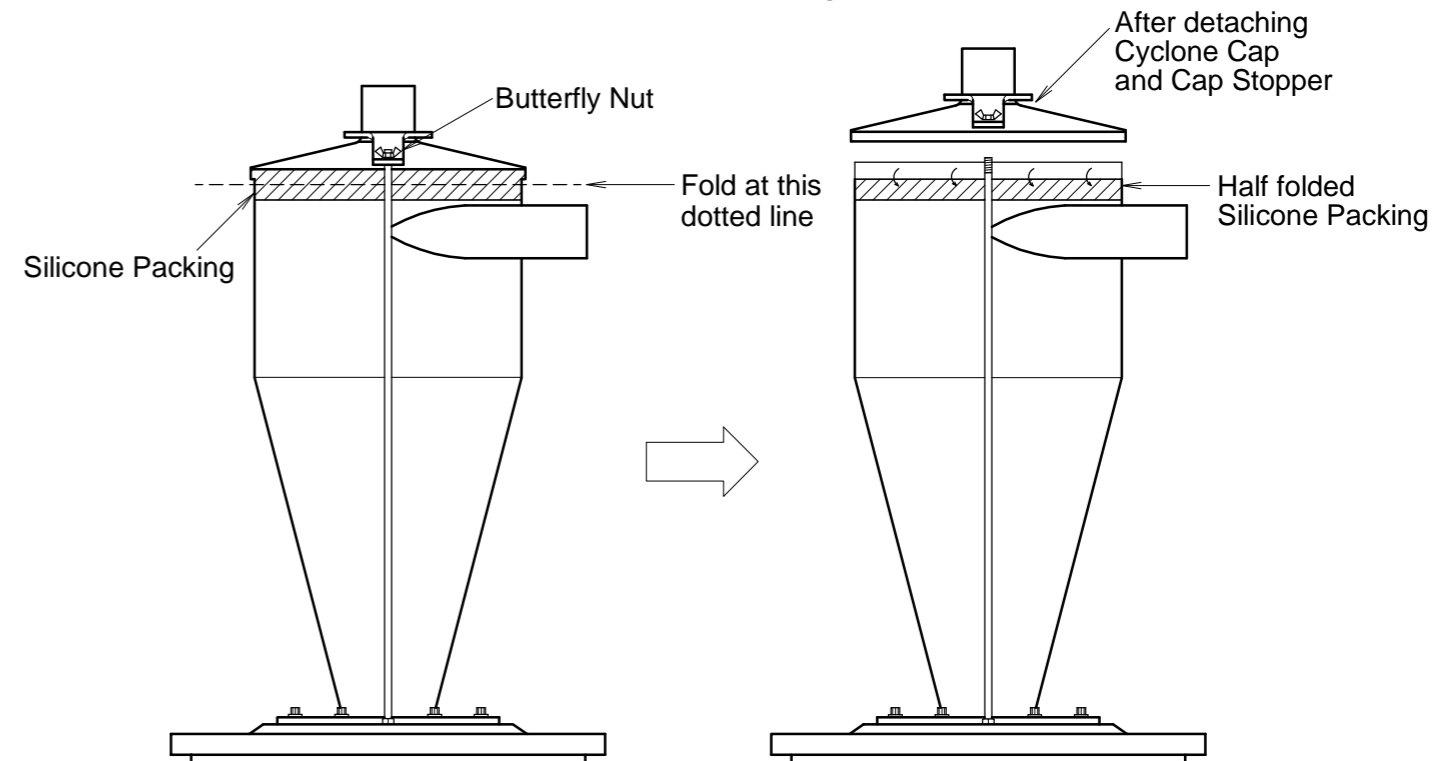

- ① Take off the hose.
 - ② Loosen the butterfly nut and take off the Cap Stopper.
 - ③ Fold the silicone packing as shown in the drawing and take off the Cyclone Cap. Silicone packing should be kept half folded on the body.
- ※ To attach the Cyclone Cap, follow the reverse order of taking off. When attaching, please make sure that the body and Cyclone Cap are not covered with any dust.

OSAWA & COMPANY

TEL: +81-6-6572-1207

FAX: +81-6-6572-1256

E-mail: osawa@osawa-company.co.jp

In case you have any inquiry, please contact the dealer or the manufacturer.